

Hydraulic Control Valves

One of the most important considerations in any fluid power system is control. If control components are not properly selected, the entire system will not function as required. Fluid power is controlled primarily through the use of control devices called Valves. The selection of these valves involves not only the type but also the size, actuating technique, and remote-control capability. There are three basic types of valves:

(1) Directional control valves,

Directional control valves determine the path, through which a fluid traverses a given circuit, For example, they establish the direction of motion of a hydraulic cylinder or motor. This control of the fluid path is accomplished primarily by check valves, shuttle valves, and two-way, three-way, and four-way directional control valves.

(2) Pressure control valves, and

Pressure control valves protect the system against overpressure, which may occur due to excessive actuator loads or due to the closing of a valve. In general pressure control is accomplished by pressure relief, pressure reducing, sequence, unloading, and counterbalance valves.

(3) Flow control valves.

In addition, fluid Flow-rate must be controlled in various lines of a hydraulic circuit. For example, the control of actuator speeds depends on Flow-rates. This Type of control is accomplished through the use of flow control valves. Non-compensated flow control valves are used where precise speed control is not required since flow rate varies with pressure drop across a flow control valve. Pressure-compensated flow control valves automatically adjust to changes in pressure drop to produce a constant flow-rate.

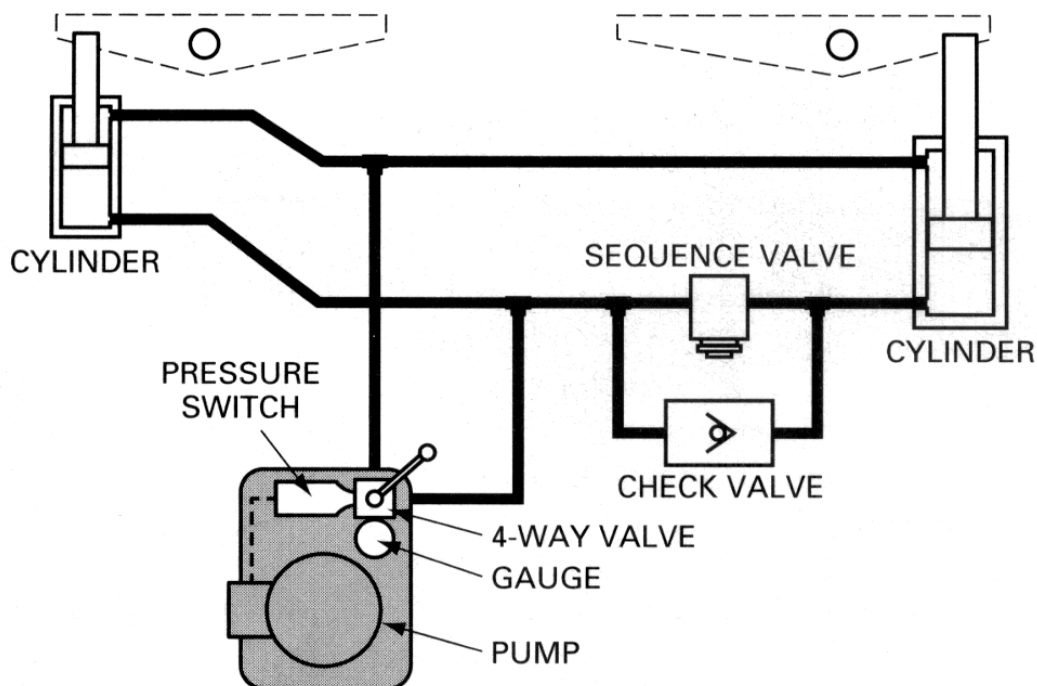

Hydraulic Circuit showing Control Valves used for Welding Application

A welding machine application in which a directional control valve, a check valve, and a sequence valve are used as components of a hydraulic circuit for positioning and holding parts during a welding operation. This particular application requires a sequencing system for fast and positive holding of these parts. This is accomplished by placing a sequence valve in the line leading to the second of the two hydraulic cylinders. When the four-way directional control valve is actuated, the first cylinder extends to the end of its stroke to complete the "positioning" cycle. Oil pressure then builds up, overcoming the sequence valve setting. This opens the sequence valve to allow oil to flow to the second cylinder so that it can extend to complete the "hold" cycle. The check valve allows the second cylinder to retract, along with the first cylinder, when the four-way valve is shifted to allow oil to flow to the rod end of both cylinders.

2- DIRECTIONAL CONTROL VALVES

As the name implies, directional control valves are used to control the direction of flow in a hydraulic circuit. Any valve (regardless of its design) contains ports that are external openings through which fluid can enter and leave via connecting pipelines. The number of ports on a directional control valve (DCV) is identified using the term way. Thus, for example, a valve with four ports is a four-way valve.

Check Valve

The simplest type of direction control valve is a check valve, which is a two-way valve because it contains two ports. The purpose of a check valve is to permit free flow in one direction and prevent any flow in the opposite direction.

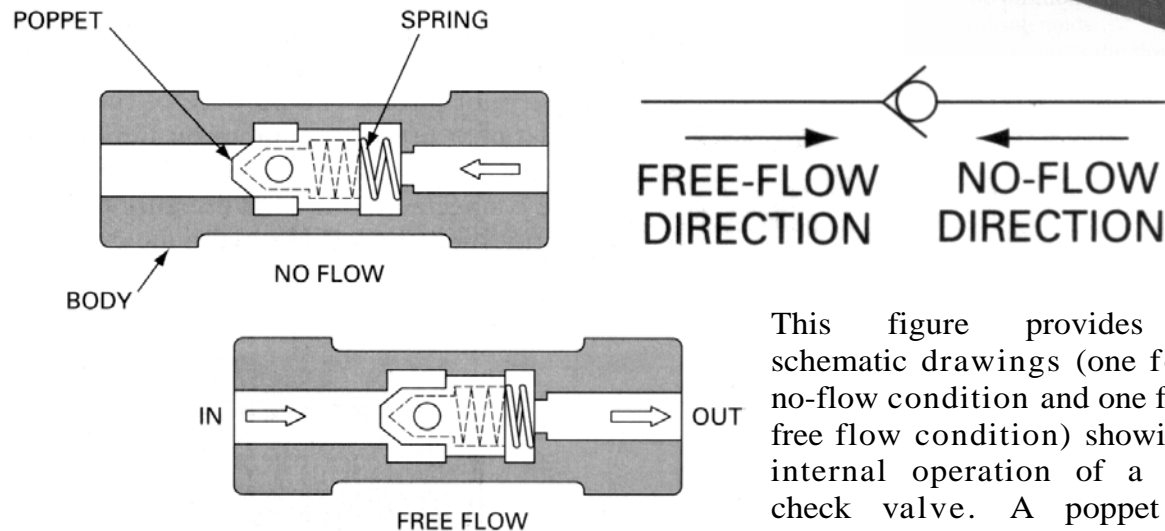

This figure provides two schematic drawings (one for the no-flow condition and one for the free flow condition) showing the internal operation of a poppet check valve. A poppet is a specially shaped plug element

held onto a seat (a surface surrounding the flow path opening inside the valve body) by a spring. Fluid flows through the valve in the space between the seal and poppet. As shown, a light spring holds the poppet in the closed position. In the free-flow direction, the fluid pressure overcomes the spring force at about 5 psi. If flow is attempted in the opposite direction, the fluid pressure pushes the poppet (along with the spring force) in the closed position. Therefore, no flow is permitted. The higher the pressure, the greater will be the force pushing the poppet against its seat. Thus, increased pressure will not

result in any tendency to allow flow in the no-flow direction. Also, the figure shows the graphic symbol of a check valve along with its no-flow and free-flow directions. Graphic symbols, which clearly show the function of hydraulic components (but without the details provided in schematic drawings), are used when drawing hydraulic circuit diagrams. Note that a check valve is analogous to a diode in electric circuits.

Pilot-Operated Check Valve

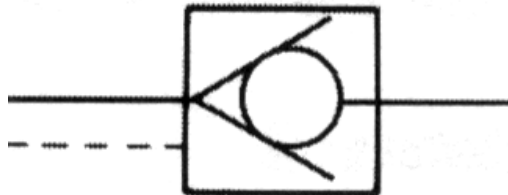

A second type of check valve is the pilot-operated check valve, shown in Figure 5 along with its graphic symbol. This type of check valve always permits free flow in one direction but permits flow in the normally blocked opposite direction only if pilot pressure is applied at the pilot pressure port of the valve.

In the design shown, the check valve poppet has the pilot piston attached to the threaded poppet stem by a nut. The light spring holds the poppet seated in a no-flow condition by pushing against the pilot piston. The purpose of the separate drain port is to prevent oil from creating a pressure buildup on the bottom of the piston. The dashed line (which is part of the graphic symbol shown) represents the pilot pressure line connected to the pilot pressure port of the valve. Pilot check valves are frequently used for locking hydraulic cylinders in position.

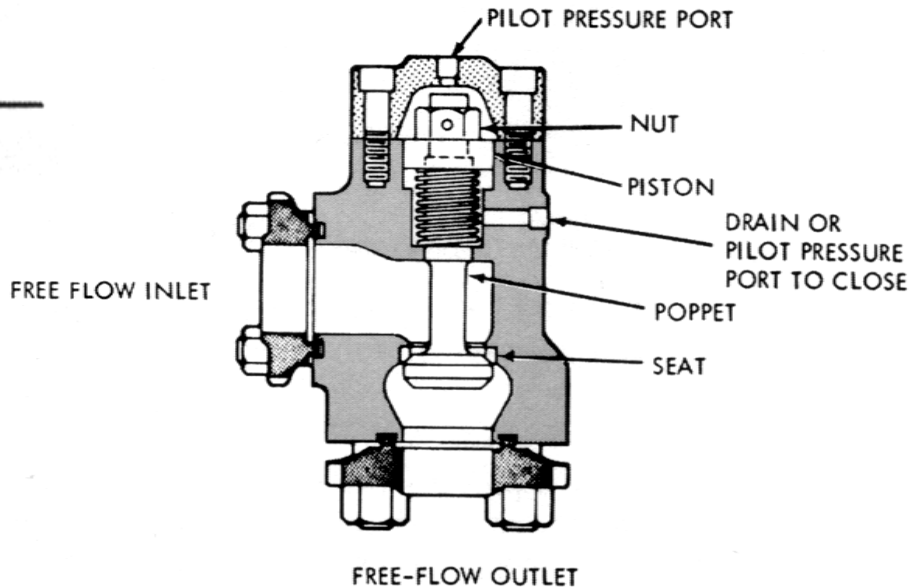

Three-Way Valves

Three-way directional control valves, which contain three ports, are typically of the spool design rather than poppet design. A spool is a circular shaft containing lands that are large diameter sections machined to slide in a very close fitting bore of the valve body. The radial clearance between the land and bore is usually less than 0.001 in. The grooves between the lands provide the flow paths between ports. These valves are designed to operate with two or three unique positions of the spool. The spool can be positioned manually, mechanically, by using pilot pressure, or by using electrical solenoids. Next figure shows the flow paths through a three-way valve that uses two positions of the spool. Such a valve is called a three-way, two-position directional control valve. The flow paths are shown by two schematic drawings (one for each spool position) as well as by a graphic symbol (containing two side-by-side rectangles). In discussing the operation of these valves, the rectangles are commonly called "envelopes."

The following is a description of the flow paths through the three-way.

Spool Position 1: Flow can go from pump port **P** (the port connected to the pump discharge pipe) to outlet port **A** as shown by the straight line and arrow in the left

envelope. In this spool position, tank port T (the port connected to the pipe leading to the oil tank) is blocked.

Spool Position 2: Flow can go from port A to port T. Port P is blocked by the spool. Note that the three ports are labeled for only one of the two envelopes of the graphic symbol. Thus the reader must mentally identify the ports on the second envelope.

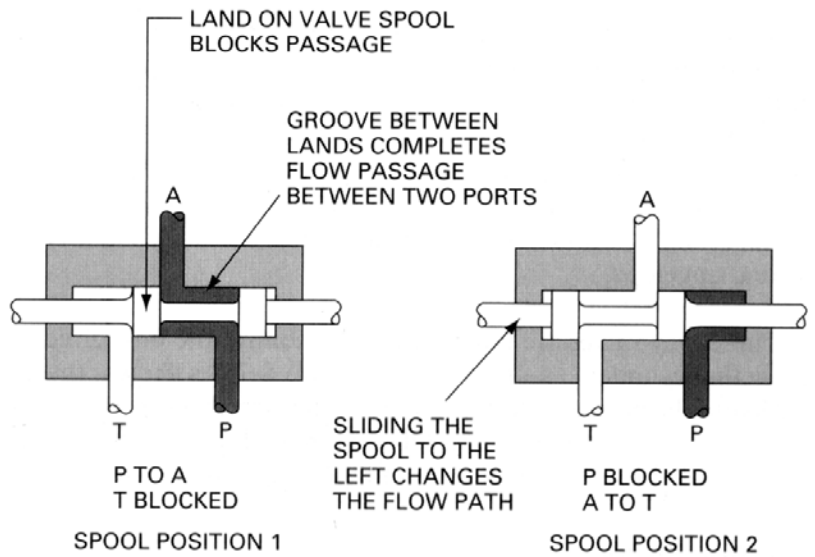
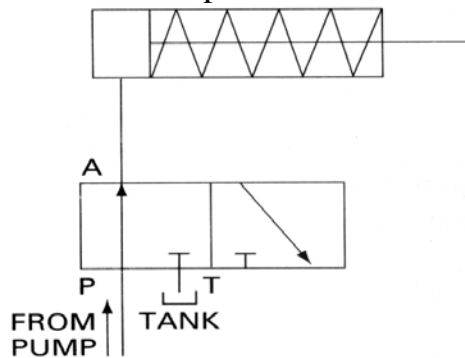

SCHEMATIC DRAWINGS

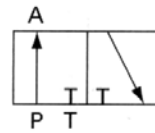

GRAPHIC SYMBOL

Three way directional control valves are typically used to control the flow directions to and from single-acting cylinders. As shown, the cylinder extends under hydraulic pressure (left envelope) and retracts under spring force as oil flows to the oil tank (right envelope). Observe that fluid entering the pump port of a three-way valve can be directed to only a single outlet port (in this case port A).

Four-Way Valves

The figure shows the flow paths through a four-way, two-position directional control valve. Observe that fluid entering the valve at the pump port can be directed to either outlet port A or B. The following is a description of the flow paths through this four-way valve:

Spool Position 1: Flow can go from P to A and B to T

Spool Position 2: Flow can go from P to B and A to T.

Observe that the graphic symbol shows only one tank port T (for a total of four ports) even though the actual valve may have two, as shown in the schematic drawings. However, each tank port provides the same function, and thus there are only four different ports from a functional standpoint. The two internal Flow-to-tank passageways can be combined

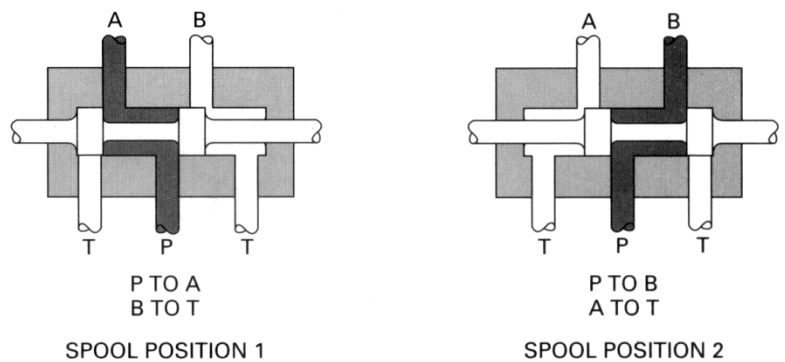

SCHEMATIC DRAWINGS

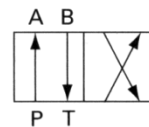

GRAPHIC SYMBOL

inside the actual valve to provide a single tank port. Recall that the graphic symbol is concerned with only the function of a component and not its internal design. Four-way valves are typically used to control the flow directions to and from double-acting cylinders, as shown in next figure. As shown, a four-way valve permits the cylinder to both extend (left envelope) and retract (right envelope) under hydraulic pressure.

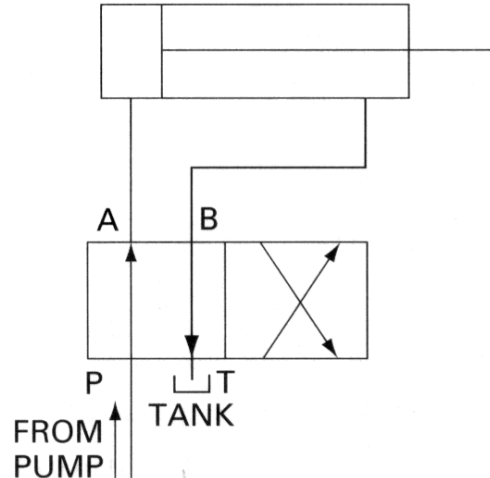

Four-Way DCV Controlling Flow Directions to and from a Double-Acting Cylinder.

Manually Actuated Valves

Manually Actuated Spring-Centered, Three-Position, Four-Way Valve is shown in figure. It is manually actuated by hand lever. Since the spool is spring loaded at both ends, it is spring-centered, three-position directional control valve. Thus, when the valve is un-actuated (no hand force on lever), the valve will assume its center position due to the balancing opposing spring forces. Note in the graphic symbol that the ports are labeled on the center envelope, which represents the flow path configuration in the spring-centered position of the spool. Also observe the spring and lever actuation symbols used at the ends of the right and left envelopes. These imply a spring centered, manually actuated valve. It should be noted that a three-position valve is used when it is necessary to stop or hold a hydraulic actuator at some intermediate position within its entire stroke range.

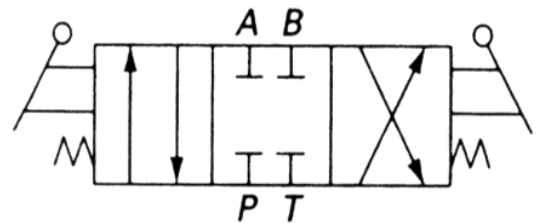

Manually Actuated Two-Position, Spring-offset, Four-Way Valve is shown in figure. In this case the lever shifts the spool, and the spring returns the spool to its original position when the lever is released. There are only two unique operating positions, as indicated by the graphic symbol. Note that the ports are labeled at the envelope representing the neutral (spring offset or return) or un-actuated position of the spool.

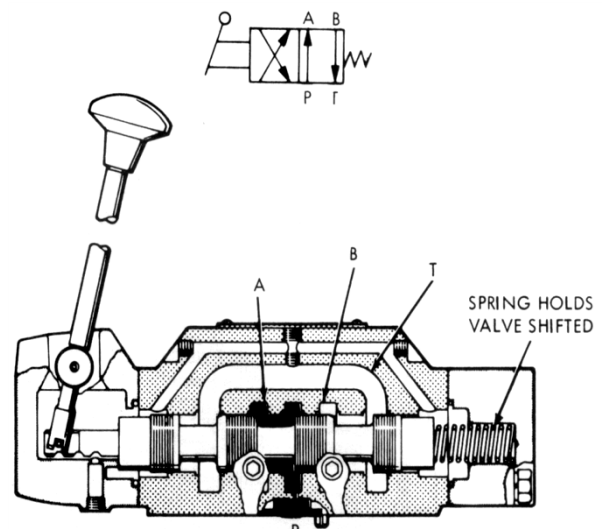

Mechanically Actuated Valves

Mechanically Actuated Spring-offset, Two-Position, Four-Way Valve is shown in figure. This is depicted in the cutaway, view, with the spool end containing a roller that is typically actuated by a cam-type mechanism. Note that the graphic symbol is the same except that actuation is depicted as being mechanical (the circle represents the cam-driven roller) rather than manual.

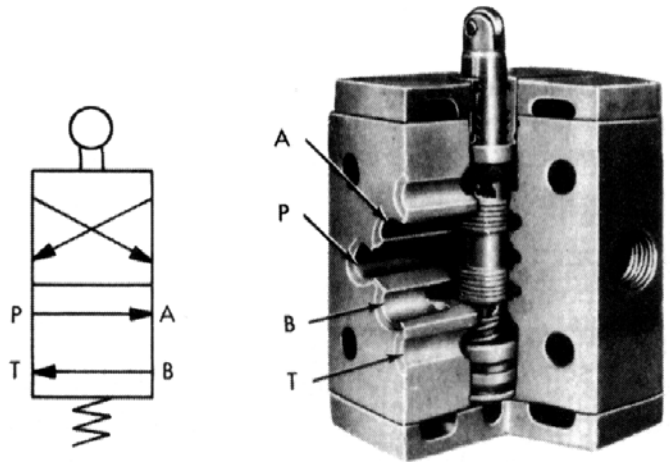

Pilot-Actuated Valves

Air Pilot-Actuated Three-Position, Spring-Centered, Four-Way Valve (DCV) is shown in figure. Directional control valves can also be shifted by applying air pressure against a piston at either end of the valve spool. As shown, springs (located at both ends of the spool) push against centering washers to center the spool when no air is applied. When air is introduced through the left end passage, its pressure pushes against the piston to shift the spool to the right. Removal of this left end air supply and introduction of air through the right end passage causes the spool to shift to the left. Therefore, this is a four-way, three-position, spring-centered, air pilot actuated directional control valve. In the graphic symbol, the dashed lines represent pilot pressure lines.

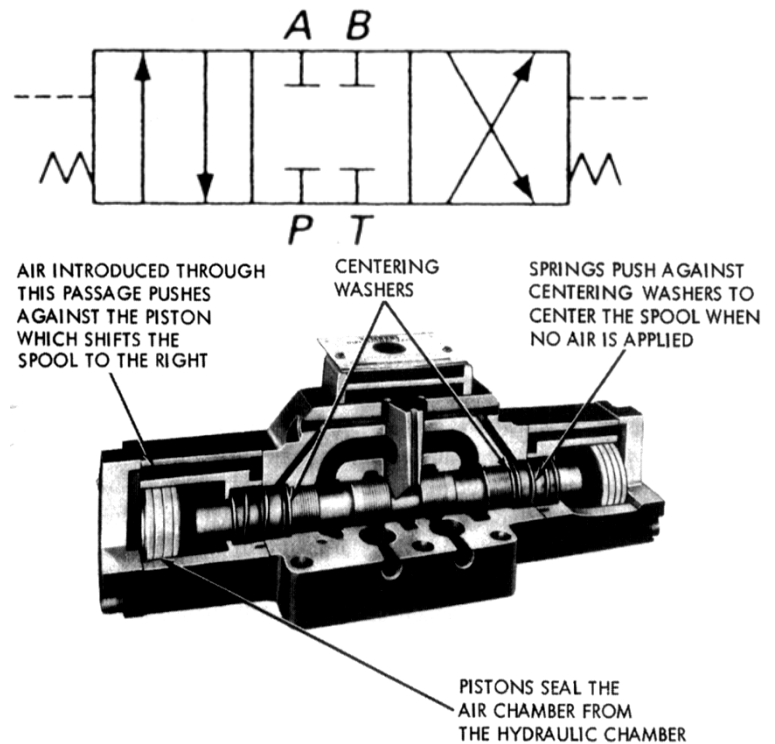

Solenoid-Actuated Valves

A very common way to actuate a spool valve is by using a solenoid as illustrated in figure. As shown, when the electric coil (solenoid) is energized, it creates a magnetic force that pulls the armature into the coil. This causes the armature to push on the push pin to move the spool of the valve.

Solenoids are actuators that are bolted to the valve housing, as shown in figure, which gives an **Solenoid-Actuated, Three-Position, Spring-Centered, Four-Way, Directional Control Valve**. Like mechanical or pilot actuators, solenoids work against a push

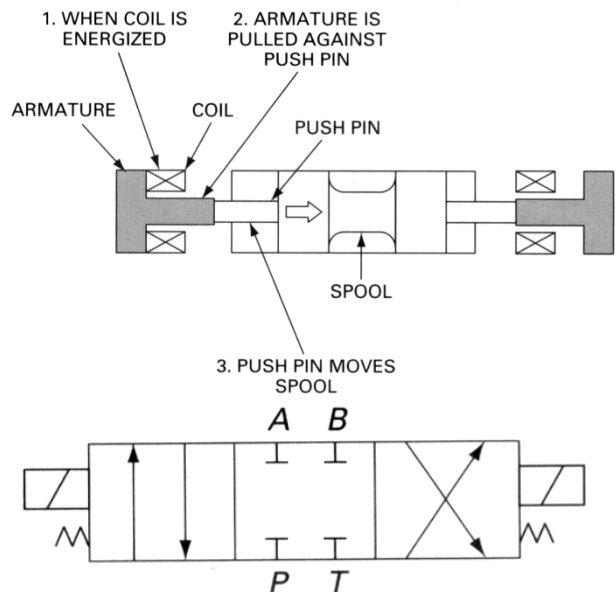

pin which is sealed to prevent external leakage of oil. There are two types of solenoid designs used to dissipate the heat created by the electric current flowing in the wire of the coil. The first type simply dissipates the heat to the surrounding air and is referred to as an air gap solenoid. In the second type, a wet pin solenoid, the push pin contains an internal passageway that allows tank port oil to communicate between the housing of the valve and the housing of the solenoid. Wet pin solenoids do a better job in dissipating heat because the cool oil represents a good heat sink to absorb the heat from the solenoid. As the oil circulates, the heat is earned into the hydraulic system where it can be easily dealt with. The solenoid valve shown has a flow capacity of 12 gpm and a maximum operating pressure of 3500 psi. It hits a wet pin solenoid whose armature moves in a tube that is open to the tank cavity of the valve. The fluid around the armature serves to cool it and cushion its stroke without appreciably affecting response time. There are no seals around this armature to wear or restrict its movement. This allows all the power developed by the solenoid to be transmitted to the valve spool without having to overcome seal friction. Impact loads, which frequently cause premature solenoid failure, are eliminated with this construction.



A single solenoid-actuated four-way, two-position, spring-offset, directional control valve is shown in the right figure.

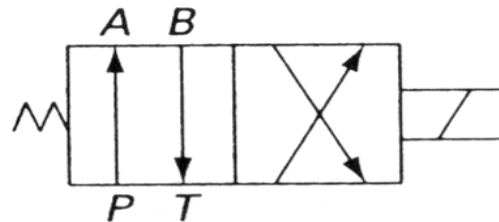

A solenoid-controlled pilot-operated directional control valve is shown in the left figure. Note that the pilot valve is actually on top of the main valve body. The upper pilot stage spool (which is solenoid actuated) controls the pilot pressure, which can be directed to either end of the main stage spool. This 35 gpm, 3000 psi valve is of the four-way, three-position, spring-centered configuration and has a manual override to shift the pilot stage mechanically when troubleshooting.

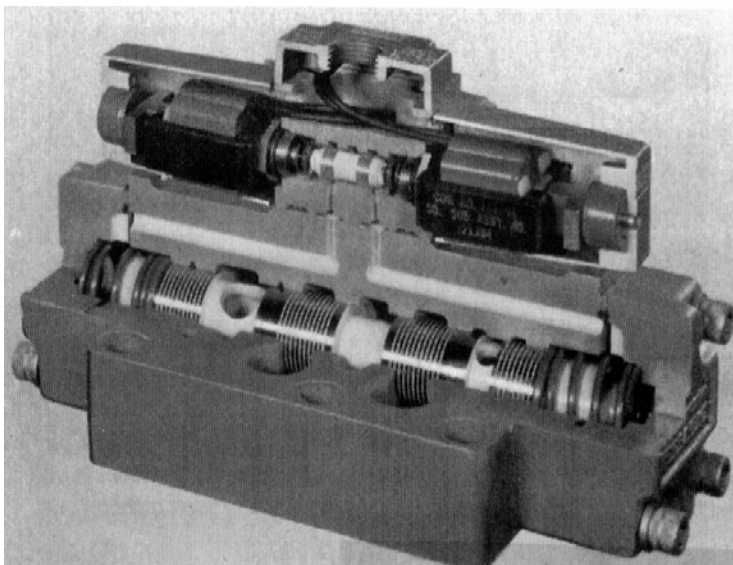

Center Flow Path Configurations for Three-Position, Four-Way Valves

Most three-position valves have a variety of possible flow path configurations. Each four-way valve has an identical flow path configuration in the actuated position but a different spring-centered flow path. Note that the open-center-type connects all ports together. In this design the pump flow can return directly back to the tank at

essentially atmospheric pressure. At the same time, the actuator (cylinder or motor) can be moved freely by applying an external force. The closed-center design has all ports blocked. In this way the pump flow can be used for other parts of the circuit. At the same time, the actuator connected to ports **A** and **B** is hydraulically locked. This means it cannot be moved by the application of an external force. The tandem design also results in a locked actuator. However, it also unloads the pump at essentially atmospheric pressure. For example, the closed-center design forces the pump to produce flow at the high-pressure setting of the pressure relief valve. This not only wastes pump power but promotes wear and shortens pump life, especially if operation in the center position occurs for long periods. Another factor is that the wasted power shows up as heat, which raises the temperature of the oil. This promotes oil oxidation, which increases the acidity of the oil. Such oil tends to corrode the critical metallic parts not only of the pump but also of the actuators and valves. Also affected is the viscosity of the oil. Higher temperature lowers the viscosity, which in turn increases leakage and reduces the lubricity of the oil. To keep the temperature at a safe level, an expensive oil cooler may be required.

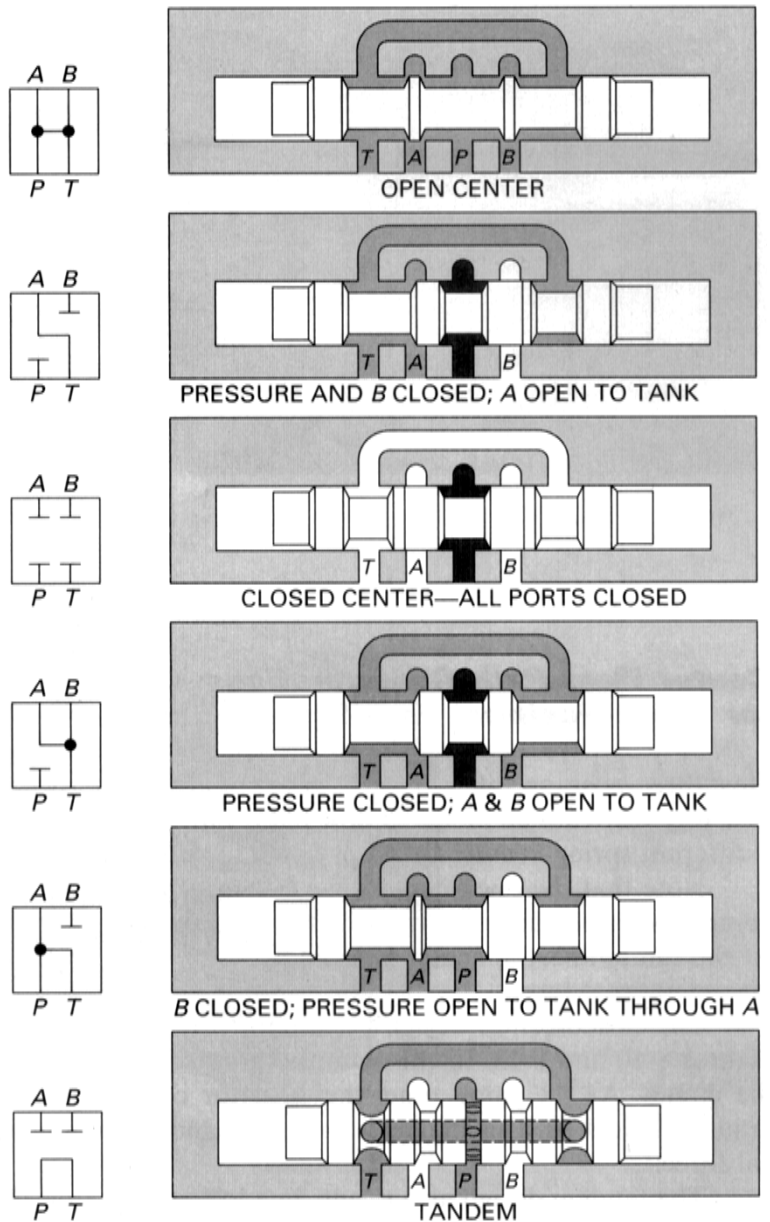

Shuttle Valves

A shuttle valve is another type of directional control valve. It permits a system to operate from either of two fluid power sources. One application is for safety in the event that the main pump can no longer provide hydraulic power to operate emergency devices. The shuttle valve will shift to allow fluid to flow from a secondary backup pump. A shuttle valve consists of a floating piston that can be shuttled to one side or the

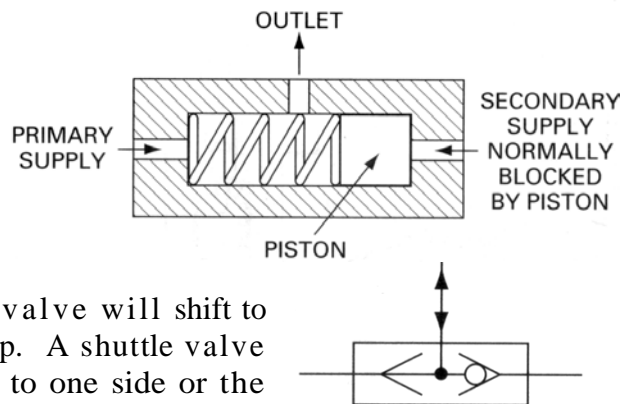

other of the valve depending on which side of the piston has the greater pressure. Shuttle valves may be spring loaded (as shown) in one direction to favor one of the supply sources or unbiased so that the direction of flow through the valve is determined by circuit conditions. A shuttle valve is essentially a direct-acting, double-check valve with a cross bleed, as shown by the symbol. Also, the double arrows means that reverse flow is permitted.

3- PRESSURE CONTROL VALVES Simple Pressure Relief Valves

The most widely used type of pressure control valve is the pressure relief valve, since it is found in practically every hydraulic system. It is normally a closed valve whose function is to limit the pressure to a specified maximum value by diverting pump flow back to the tank. **The operation of a simple relief valve** is shown in figure.

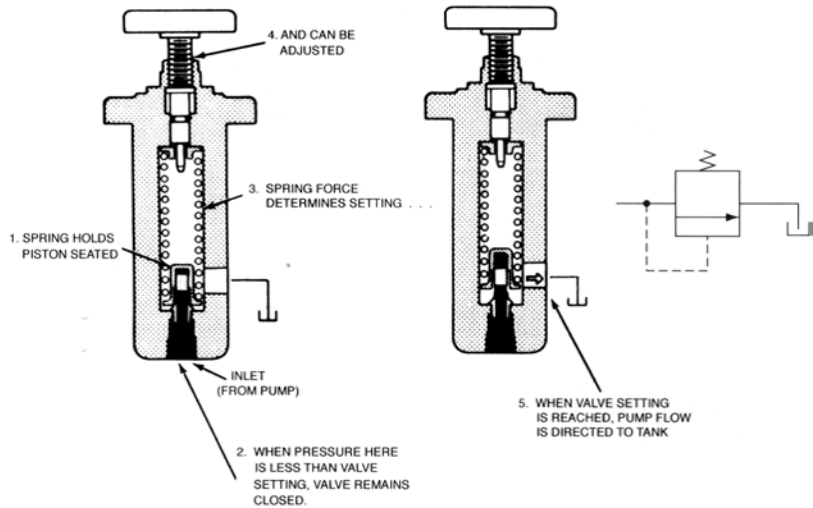

A poppet is held seated inside the valve by the force of a stiff compression spring: When the system pressure reaches a high enough value, the resulting hydraulic force (acting on the piston-shaped poppet) exceeds the spring force and the poppet is forced off its seal. This permits flow through the outlet to the tank as long as this high pressure level is maintained. Note the external adjusting screw, which varies the spring force and, thus, the pressure at which the valve begins to open (cracking pressure).

It should be noted that the poppet must open sufficiently to allow full pump flow. The pressure that exists at full pump flow can be substantially greater than the cracking pressure. **Pressure is plotted versus flow through the relief valve** in figure.

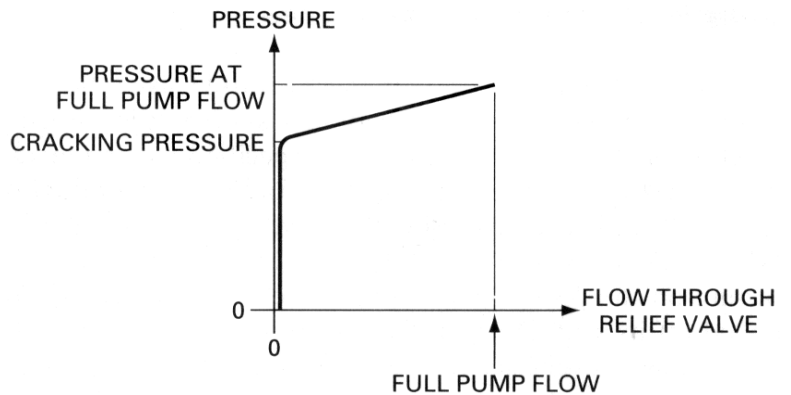

The stiffness of the spring (force required to compress the spring 1 in or 1 cm) and the amount the poppet must open to permit full pump flow determine the difference between the full pump flow pressure and the cracking pressure. The stiffness of a spring is called the spring constant and has units of lb/in or N/cm. The pressure at full pump flow is the pressure level that is specified when referring to the pressure setting, of the relief valve. It is the maximum pressure level permitted by the relief valve.

A partial hydraulic circuit containing a pump and pressure relief valve, which are drawn symbolically, is shown in figure. If the hydraulic system (not shown) does not accept any

flow, then all the pump flow must return to the tank via the relief valve. The pressure relief valve provides protection against any overloads experienced by the actuators in the hydraulic system. Obviously one important function of a pressure relief valve is to limit the force or torque produced by hydraulic cylinders and motors.

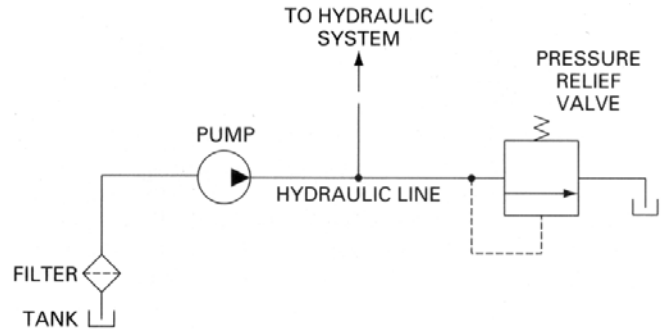

4- FLOW CONTROL VALVES

Orifice as a Flow Meter or Flow Control Device

An orifice (a disk with a hole through which fluid flows) installed in a pipe can be used as a flow meter by measuring the pressure drop (Δp) across the orifice. This is because for a given orifice, there is a unique relationship between (Δp) and Q (the flow-rate through the orifice and thus the flow rate in the pipe). It can be shown that the following English-units equation relates the (Δp) vs. Q

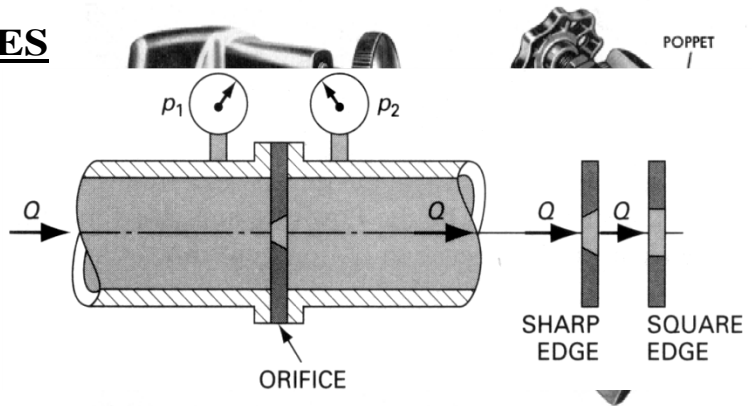

relationship for an orifice installed in a pipe to measure liquid flow rate.

$$Q = 38.1 CA \sqrt{\frac{\Delta p}{SG}} \quad \text{Or, in metric units,} \quad Q = 0.0851 CA \sqrt{\frac{\Delta p}{SG}}$$

where

Q = flow-rate (gpm, Lpm).

C = flow coefficient ($C = 0.80$ for sharp-edged, orifice, $C = 0.6$ for square-edged orifice).

A = area of orifice opening (in^2, mm^2).

$\Delta p = p_1 - p_2$ = pressure drop across orifice (psi, kPa)

SG = specific gravity of flowing fluid.

As seen from equation, the greater the flow-rate, the greater will be the pressure drop and vice versa for a given orifice. An orifice can also be used as a flow control device. As seen from equation, the smaller the orifice area, the smaller will be the flow-rate and vice versa for a given pressure drop. This leads us to the discussion of flow control valves.

Needle Valves

Flow control valves are used to regulate the speed of hydraulic cylinders and motors by controlling the flow-rate to these actuators. They may be as simple as a fixed orifice or an adjustable needle valve. Needle valves are designed to give fine control of flow in small-diameter piping. Their name is derived from their sharp, pointed conical disk and matching seal, as shown in figure. The graphic symbol

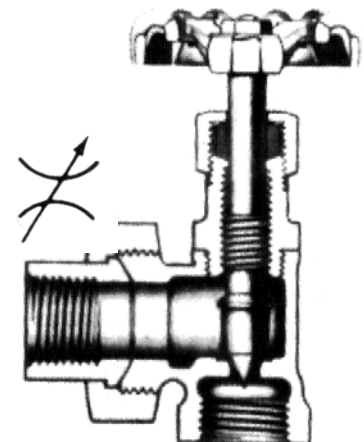

for a needle valve (which is a variable orifice) is also shown.

Figure shows **Read and Adjust Flow Control Valve**. The stem has several color rings, which, in conjunction with a numbered knob, permits of a given valve opening as show. Charts are available that allow quick determination of the controlled flow-rate for given valve settings and pressure drops. A locknut prevents unwanted changes in flow.

For a given operating position, a needle valve behaves as an orifice. However unlike an orifice, the flow area (A) in a needle valve can he varied. The equation represent the pressure drop versus flow-rate for a needle valve will be.

$$Q = C_v \sqrt{\frac{\Delta p}{SG}}$$

where Q = volume flow-rate (gpm, Lpm),

C_v = capacity coefficient (gpm/ $\sqrt{\text{psi}}$, Lpm/ $\sqrt{\text{kPa}}$),

Δp = pressure drop across the valve (psi, kPa),

SG = specific gravity of the liquid.

In English units, the capacity coefficient is defined as the flow-rate of water in gpm that will flow through the valve at a pressure drop of 1 psi.

In metric units the capacity coefficient is defined as the flow-rate of water in Lpm (liters per minute) that will flow through the valve at a pressure drop of 1 kPa.

The value C_v is determined experimentally for each type of valve in the fully open position and is listed as the "rated C_v " in manufacturers' catalogs.